

TECWARE

VXM²

DUAL CHAMBER MATX CASE

Quick Start Guide

Contents

◆ Specification	p.01
◆ Panel Removal	p.02
◆ Front Panel I/O Connections	p.03
◆ Component List	p.04
◆ Motherboard Installations	p.05
◆ SSD / HDD Installation	p.06
◆ GPU & PSU Installation	p.07
◆ CPU Cooler / Fan Installation	p.08
◆ Package Contents & Warranty	p.09

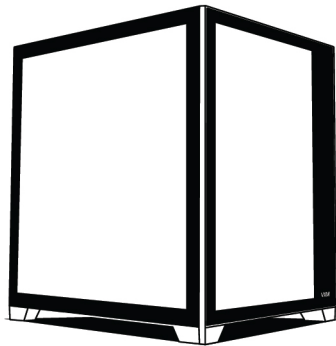

Specifications

Type	Specification
Motherboard Support	mATX, ITX
Dimensions	345(L) x 270(W) x 375(H) mm
3.5" HDD Drive Bay	2
2.5" SSD Drive Bay	1
Expansion Slots	4
Maximum GPU Length	320mm
Maximum CPU Cooler Height	155mm
Maximum PSU Length	160mm

Panel Removal

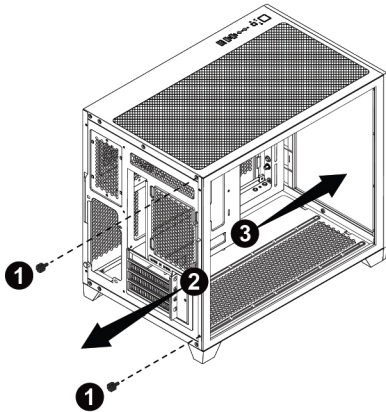

- 1) Unscrew side panel thumb screws.
- 2) Slide side panels back to release.
- 3) Gently push the front glass panel from the inside of the case.

Front Panel I/O Connections

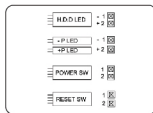

BUTTONS AND ACTIVITY LIGHTS

These cables are connected to the motherboard for the power button (power sw), reset button, HDD LED, and power LED (P+ / P-).

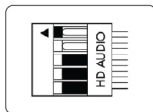

HD AUDIO

This connector attaches to your sound card or motherboard and is used to provide the front panel mic input and headphone output.

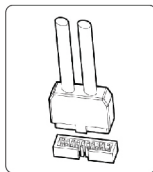



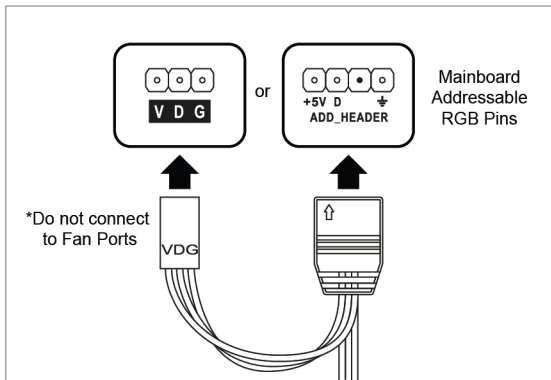

USB 3.0 CONNECTOR

This cable connects to the USB 3.0 header on the motherboard to enable the front USB 3.0 ports.

Fan ARGB Connections



Component List

VISUAL	ITEM	QTY	APPLICATION
A 	Motherboard & SSD screw	16	Motherboard and 2.5 hard drive installation
B 	Motherboard standoff	3	Motherboard installation
C 	HDD mount screw	8	3.5 hard drive installation
D 	PSU & Rear expansion slot screw	5	Power supply installation Mounting of GPU and other expansion cards
E 	Cable tie	5	Cable management

Motherboard Installation

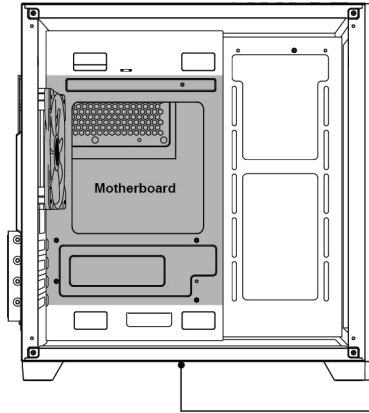

Screw Type A & B

SSD / HDD Installation

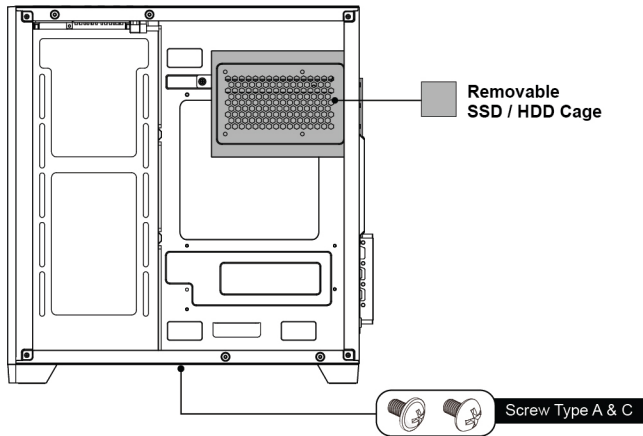

GPU & PSU Installation

Graphics Processing Unit and other expansion cards

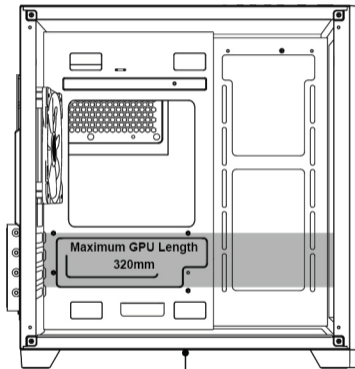

Power Supply Unit Installation

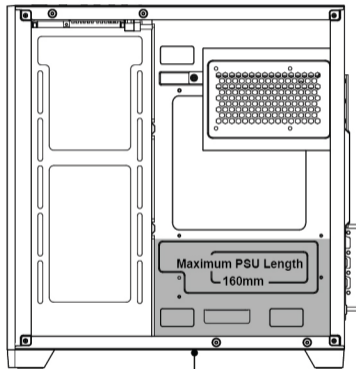

Screw (Type D)

CPU Cooler / Fan Installation

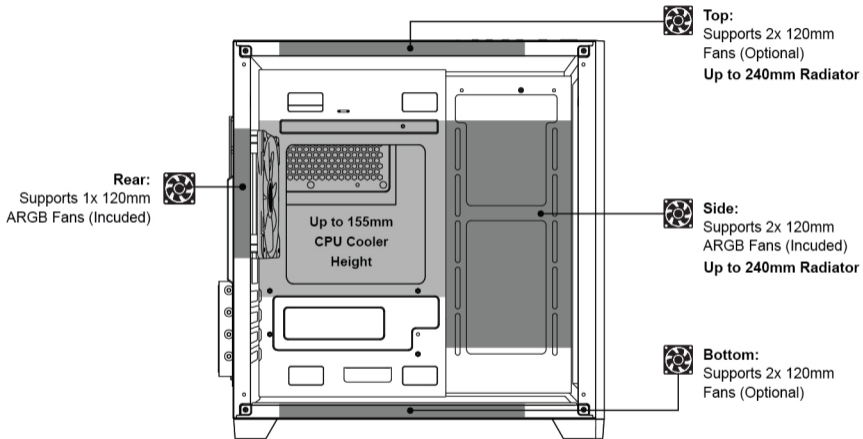

Package Contents

- 1 x TECWARE VXM2 Case
- 1 x Bag of Accessories

Warranty

- 1 Year. Please contact your local distributor for support.

T E C W A R E

www.tecware.co