

TECWARE

VXM

DUAL CHAMBER SFF CASE

TEMPERED GLASS

Quick Start Guide

# Contents

◆ Specification .....	p.01
◆ Panel Removal .....	p.02
◆ Front Panel I/O Connections .....	p.03
◆ Component List .....	p.04
◆ Motherboard Installations .....	p.05
◆ SSD / HDD Installation .....	p.06
◆ GPU & PSU Installation .....	p.07
◆ CPU Cooler / Fan Installation .....	p.08
◆ Package Contents & Warranty .....	p.09

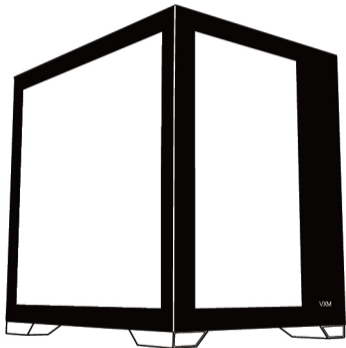

## Specifications

Type	Specification
Motherboard Support	mATX, ITX
Dimensions	338(L) x 255(W) x 335(H) mm
3.5" HDD Drive Bay	1
2.5" SSD Drive Bay	3
Expansion Slots	4
Maximum GPU Length	320mm
Maximum CPU Cooler Height	140mm
Maximum PSU Length	160mm

## Panel Removal

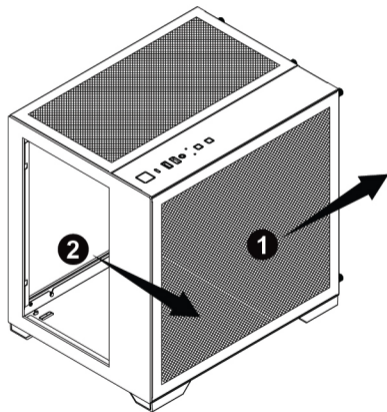
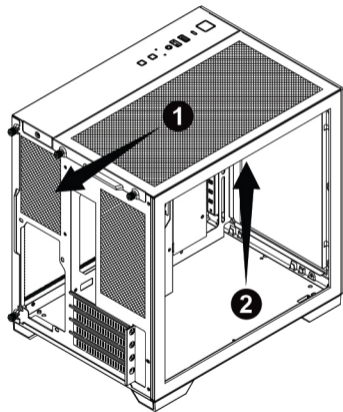

## Front Panel I/O Connections

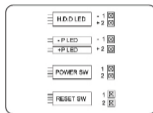

### BUTTONS AND ACTIVITY LIGHTS

---

These cables are connected to the motherboard for the power button ( power sw ), reset button, HDD LED, and power LED ( P+ / P- ).

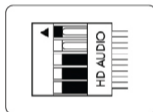

### HD AUDIO

---

This connector attaches to your sound card or motherboard and is used to provide the front panel mic input and headphone output.

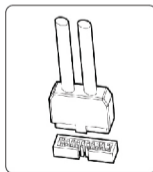





### USB 3.0 CONNECTOR

---

This cable connects to the USB 3.0 header on the motherboard to enable the front USB 3.0 ports.

## Component List

VISUAL	ITEM	QTY	APPLICATION
A 	Motherboard & SSD screw	10	Motherboard and 2.5 hard drive installation
B 	Motherboard standoff	3	Motherboard installation
C 	HDD mount screw	4	3.5 hard drive installation
D 	PSU & Rear expansion slot screw	5	Power supply installation Mounting of GPU and other expansion cards
E 	Cable tie	7	Cable management

## Motherboard Installation

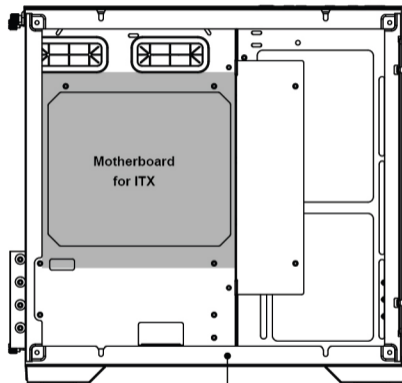
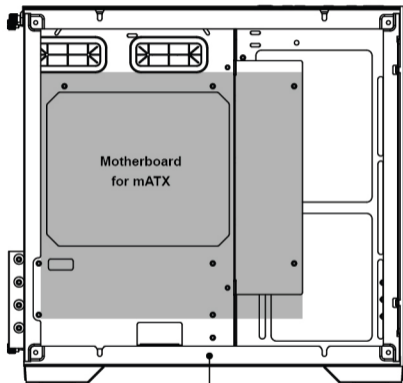

Screw (Type A & B)

# SSD / HDD Installation

## SSD Drive Installation

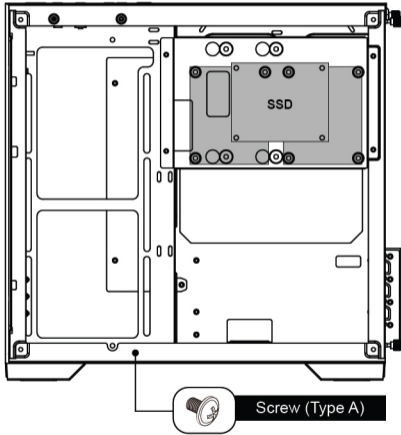

## HDD Drive Installation

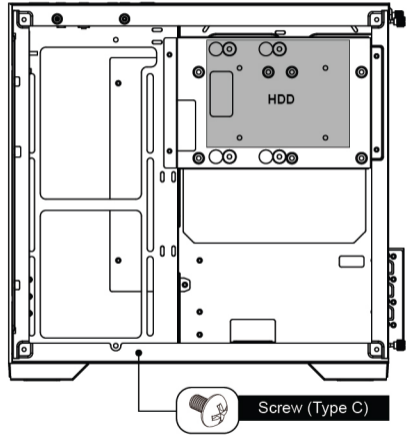



## GPU & PSU Installation

Graphics Processing Unit and other expansion cards

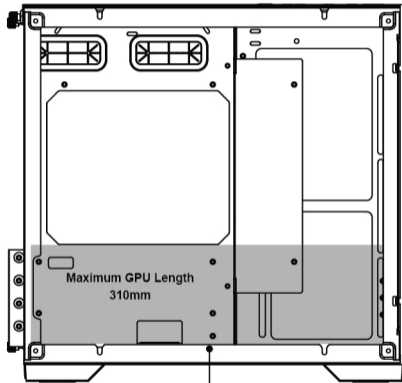

Power Supply Unit Installation

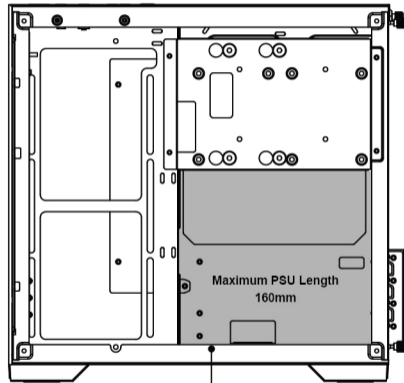

Screw (Type D)

## CPU Cooler / Fan Installation

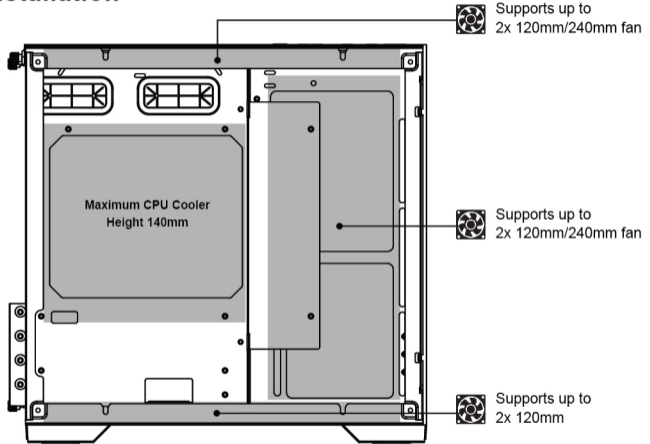

## **Package Contents**

- 1 x TECWARE VXM Case
- 1 x Bag of Accessories

## **Warranty**

- 1 Year. Please contact your local distributor for support.

T E C W A R E

[www.tecware.co](http://www.tecware.co)